

Anti-Skid Braking System for the Eclipse 500/550

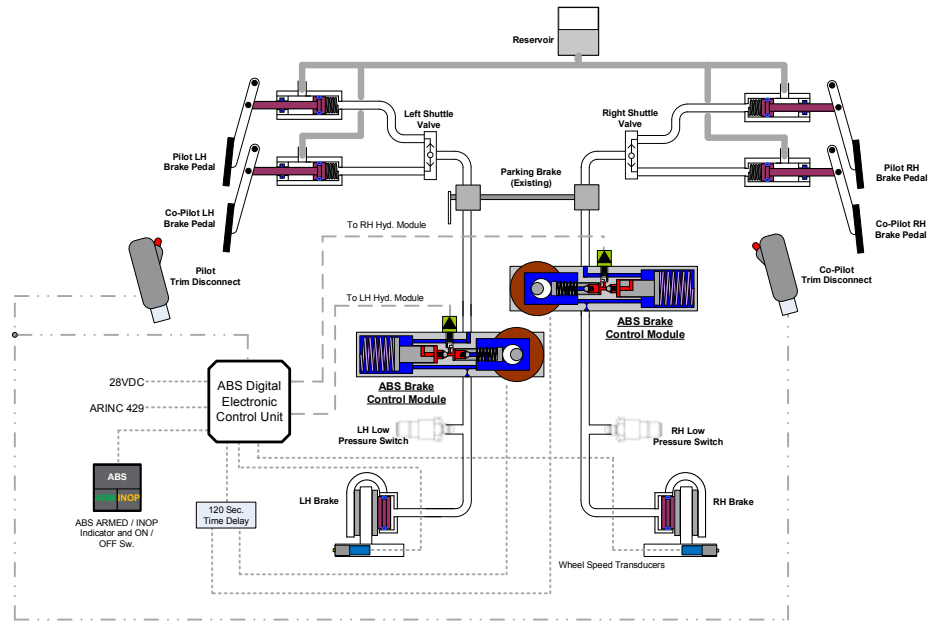

For eABS installation and technical support for your Eclipse 500/550, contact:

Eclipse Aerospace
(505) 245-7555

Advent Aircraft Systems
(918) 388-5940



Developed by:



“This system has exceeded our performance expectations, while experiencing no flat-spotting, skidding or tire failure during aggressive ABS ground and flight testing.”
Cary Winter, CEO - Resurgent Aviation
Former Senior VP Engineering
Eclipse Aerospace

“eABS in our plane has been flawless and a great peace-of-mind component. We know it’s there when we might need it. Landed one time at dusk with a runway we didn’t know was half iced up. eABS did a great job.”
Shawn Chaney
Owner EA500 N941CM

“My home airport is often snow covered. What a difference my eABS brakes make when landing on snow! I just push hard on the brakes, and the pedals do a little dance almost all the way. Well worth the price!”
Jeff Rubenstein
Owner EA500 N800JR

Introducing the breakthrough technology Advent eABS™, which brings anti-skid braking for the first time to aircraft with manual braking systems.

Certified for the Eclipse 500/550 in 2013, with over 130 aircraft equipped to date, the proven Advent eABS enables worry-free, effective and performance-enhancing anti-skid braking in all runway conditions.

The lightweight system optimizes the landing performance and braking/stopping capabilities of the Eclipse, allowing the pilot to immediately apply full braking on all surfaces, safely and reliably, with full directional control and tactile feedback from the pedals.

Weighing only 38 pounds, the easily-installed system does not require modification to the existing landing gear or master cylinders. *IFMS 2.08 software is required for installation.*



Go Ahead. Stand on the Brakes

System Performance - Better directional control and reduced stopping distance on runways contaminated with debris, water, ice and snow.

Tire Protection - Eliminates flat-spotted and blown tires during aggressive stopping on dry or contaminated runways.

Tactile Feedback - During anti-skid operation, the brake pedal pushes back, annunciating its operation. This feature will aid the pilot in knowing the braking limits of the airplane.

Low-Speed Cut-out - The system will not operate, in anti-skid mode, when aircraft speed is below 10 knots.

Touchdown Protection - Wheel speed must spin up to at least 85% of aircraft speed before brakes will operate.

Customer Service & Warranty - Eclipse technical support, backed by Advent Aircraft Systems, is available on call or in the field. All new eABS components are covered by a two year warranty.

ABS Simplicity

The patented Advent eABS system consists of left and right Brake Control Modules, left and right Wheel-Speed Transducers, a Digital Electronic Control Unit and a cockpit Control Switch and Annunciator.

Certified

The eABS installation is certified in all countries which have certified the Eclipse 500/550. The eABS has MEL relief. LRU maintenance is On-Condition, thanks to a completed 20,000 flight cycle test, with a visual inspection at 1500 flight hours.

Convenient and Affordable

The eABS is standard equipment on the Eclipse 550 and available as a Service Bulletin exclusively through Eclipse Aerospace. The easy-to-install Service Bulletin requires minimal downtime.